

DESCRIPTION

The TU-652M AS is a highly intelligible driver unit suited to public address announcement applications. Use the driver unit in combination with a suitable horn (optional). Its powder-coated finish and stainless steel screws ensure the unit's weatherproof capability.

SPECIFICATIONS

Applicable Horn	TH-652 AS
Rated Input	50 W
Line Voltage	100 V line or 70 V line
Rated Impedance	100 V line: 200 Ω (50 W), 330 Ω (30 W), 670 Ω (15 W) 70 V line: 100 Ω (50 W), 200 Ω (25 W), 330 Ω (15 W), 670 Ω (7.5 W)
Output Sound Pressure Level	110 dB (1 W, 1m) (When operated with JIS C 5504 standard horn.)
Frequency Response	150 - 6,000 Hz (When operated with JIS C 5504 standard horn.)
IP Code	IP 65 (When a driver is operated with a horn.)
Horn Coupling	1 - 3/8 18 threads (inch screw)
Polarity	Hot: Black, Com: White
Operating Temperature	-20° C to +55° C (-4° F to 131° F) (must be free from dew condensation)
Finish	Upper cover: Aluminum, White, powder coating Trans case: HIPS, White Screws: Stainless steel Speaker cable: Polyvinyl chloride insulated cabtyre cable (6 mm (0.24") in diameter, 450 mm (17.72") in length), White
Dimensions	∅139 X 149 (D) mm (∅5.47" X 5.87")
Weight	2.7 kg (5.95 lb)

APPEARANCE

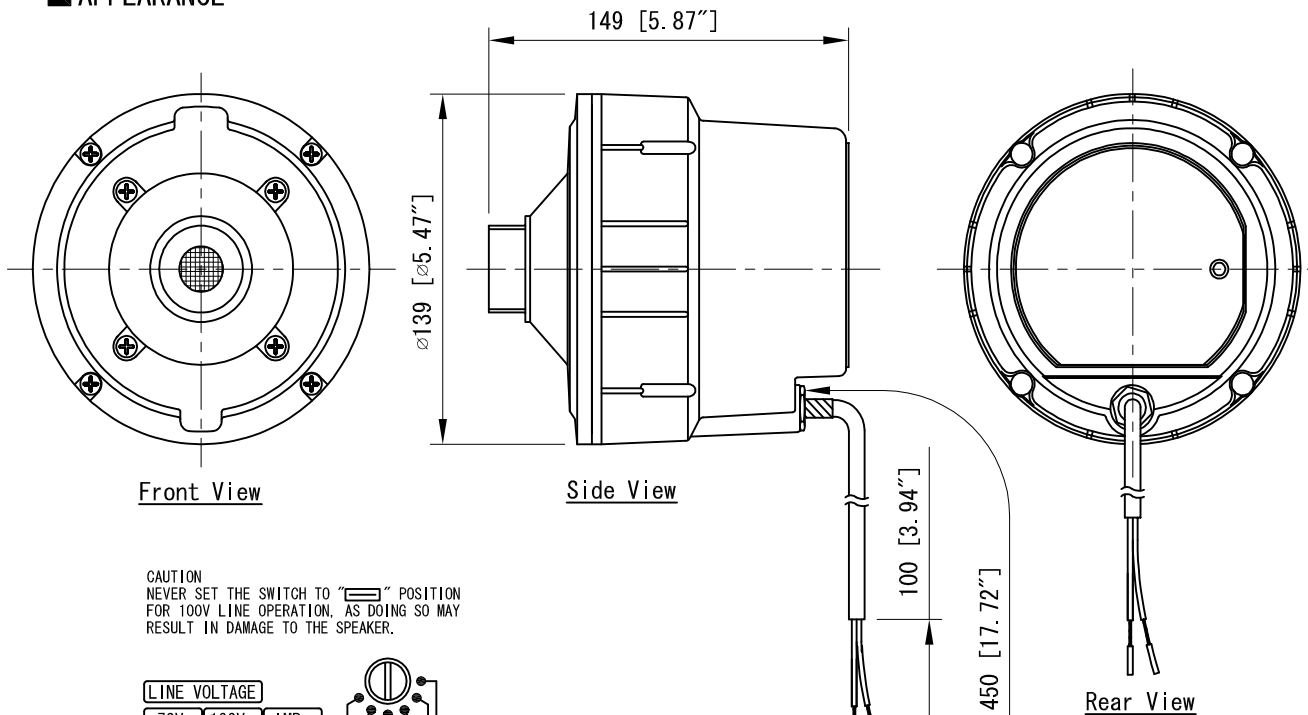

CAUTION
NEVER SET THE SWITCH TO "100V" POSITION FOR 100V LINE OPERATION. AS DOING SO MAY RESULT IN DAMAGE TO THE SPEAKER.

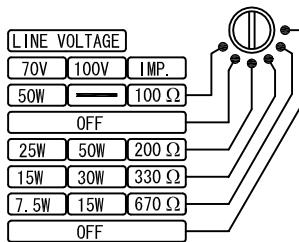

Set the impedance selector to the desired impedance
Impedance Selection

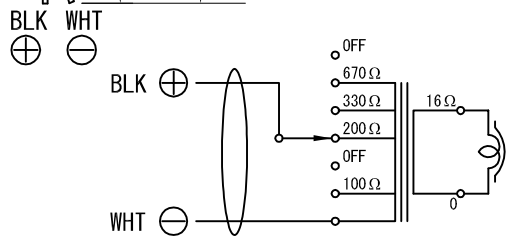

(Transformer connection when the speaker is supplied from factory)

Wiring diagram

UNIT:mm SCALE:1/3