

DESCRIPTION

The HY-0852ST bracket is used in combination with its optional speaker mounting bracket HY-B0801, HY-C0801 or HY-W0801 to horizontally mount TOA's ES-0851 speaker system to a ceiling or wall or hang the speaker system from a ceiling pipe.

SPECIFICATIONS

Usable Speaker	ES-0851
Finish	Rolled steel plate, black, semi-mat paint
Permissible Speaker Load	28 kg
Weight	3.4 kg
Accessory	Speaker mounting bolt 4
Option	Mounting bracket: HY-B0801, HY-C0801, HY-W0801

APPEARANCE

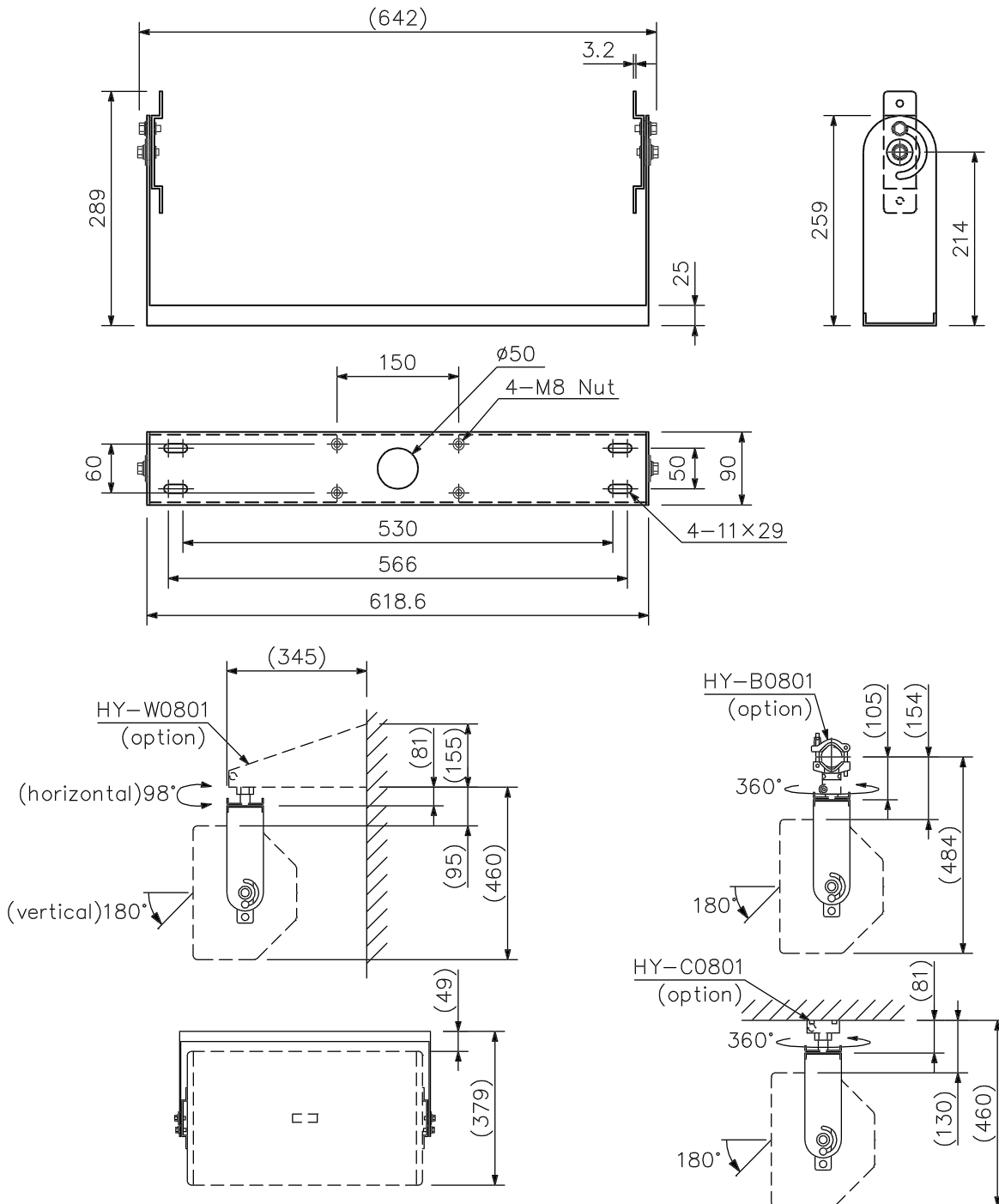

UNIT:mm SCALE:1/8

ES-0851 mounting example