

DESCRIPTION

The ES-0851 is a heavy-duty two-way speaker system designed for use in both temporary and permanent installations. Properly-designed built-in passive network ensures superb quality and high power handling capability. The speaker's 90-degree wedge shape and its optional mounting bracket permit the speaker to be mounted closely to walls and ceilings.

SPECIFICATIONS

Enclosure	Bass-reflex type
Power Handling Capacity	Continuous pink noise: 200 W Continuous program: 600 W
Rated Impedance	8 Ω
Sensitivity	97 dB (1 W, 1 m)
Frequency Response	80 Hz - 20 kHz
Crossover Frequency	1.8 kHz
Speaker Component	Low frequency: 25 cm cone-type High frequency: CD horn (90° horizontal × 60° vertical or 60° horizontal × 90° vertical) fitted with compression driver
Input Connector	Neutrik NL4MP × 2 and M5 screw terminal, distance between barriers: 12.2 mm
Finish	Enclosure : Plywood, black, urethane paint Front grille: Steel plate, black, acrylic paint
Dimensions	580 (W) × 330 (H) × 255 (D) mm
Weight	20 kg
Option	Mounting bracket: HY-0851ST, HY-0852ST, HY-0851CL, HY-B0801, HY-C0801, HY-W0801 Speaker stand: ST-34B (Can be used either alone or in combination with HY-0851ST.)

APPEARANCE

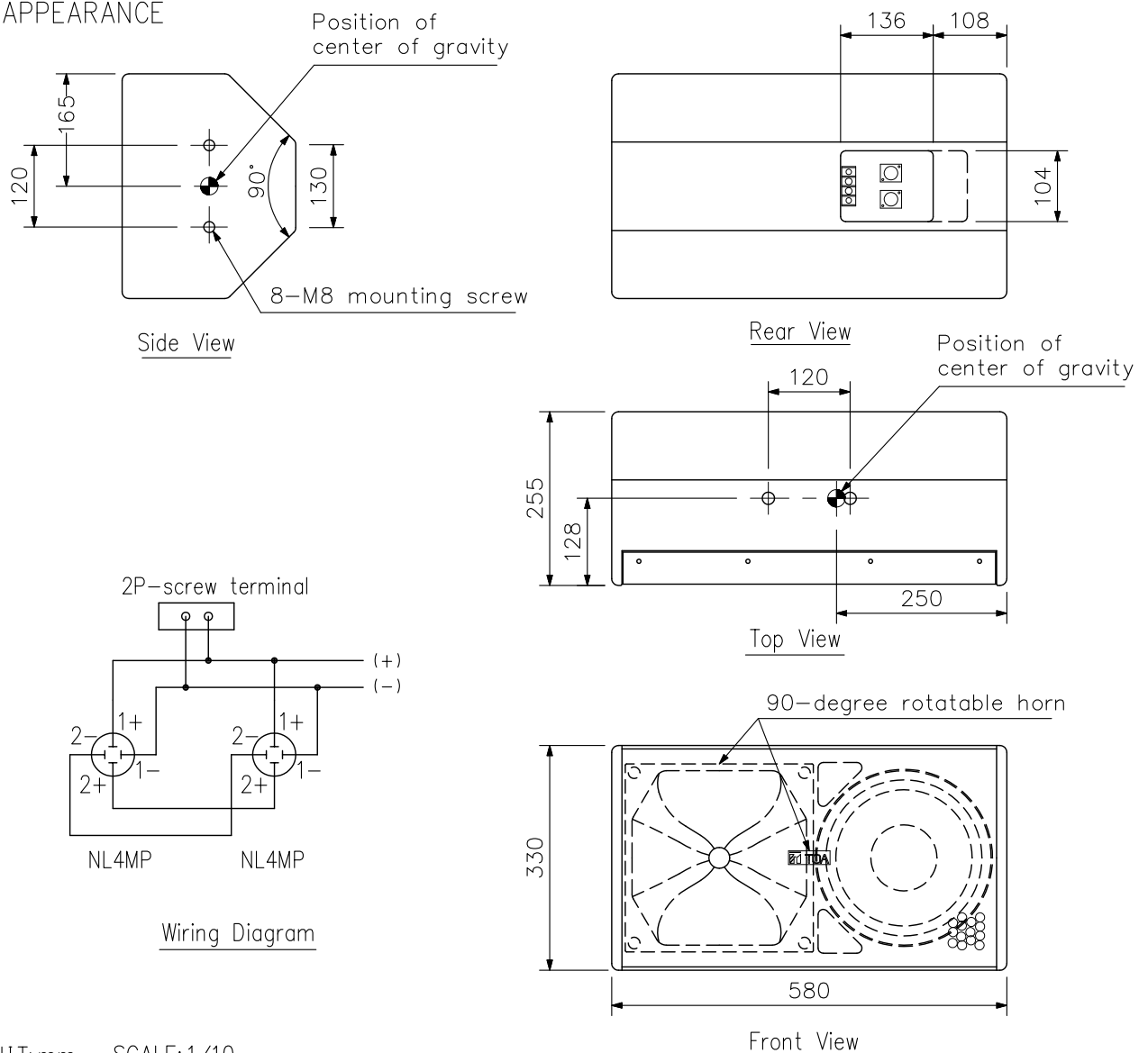

UNIT:mm SCALE:1/10