

■DESCRIPTION

The PS-011B is a power remote switch panel that can be used for rack-mount application.

■SPECIFICATIONS

Type	Power Remote Switch
Switch Capacity	5 A at 250 V AC 10 A at 125 V AC
Finish	Panel: Surface-treated steel plate, black, 30% gloss, paint
Dimensions	483 (W) × 44.5 (H) × 90 (D) mm
Weight	650 g
Accessory	Rack mounting screw (with washer) 4, Fuse 1

■APPEARANCE

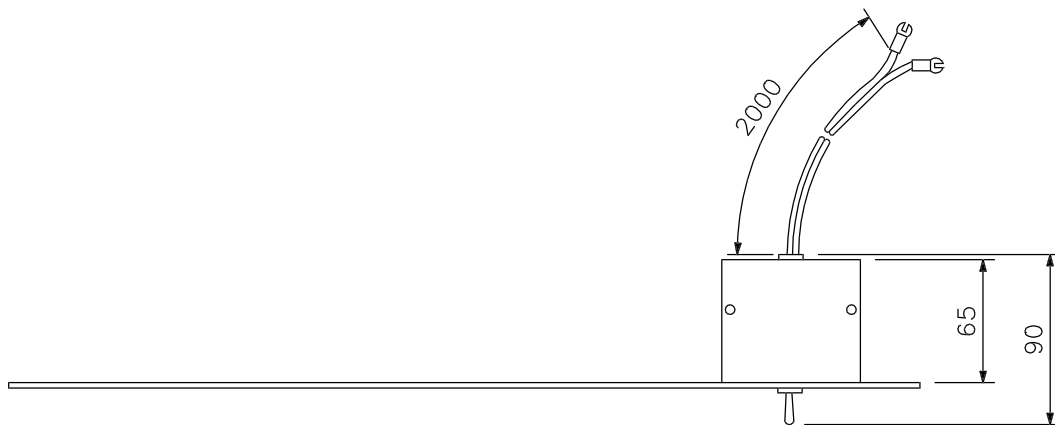

Top View

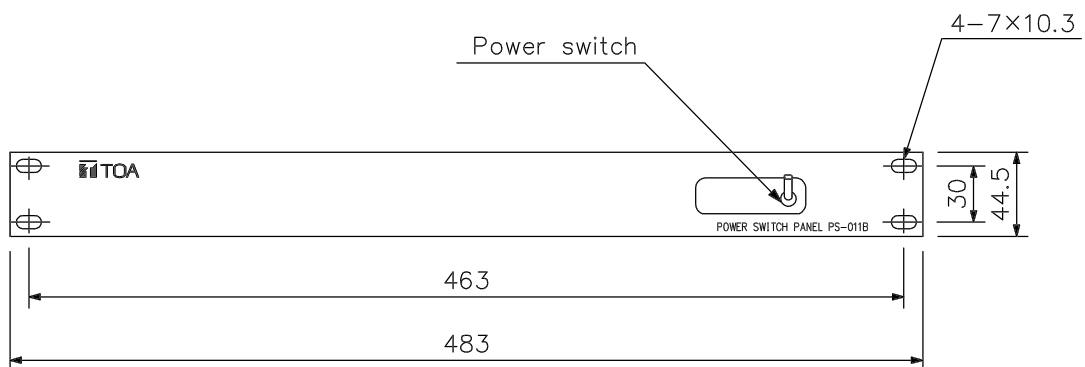

Front View

UNIT:mm SCALE:1/4